



USER GUIDE

Argo-POWER^{LM}

v2.0



Table of contents

1. Introduction	1
2. First use	2
2.1. Parcel verification	2
2.2. Quick start procedure	2
3. General handling and care	4
3.1. Handling and storage	4
3.2. Cleaning	5
3.3. Operating environment	5
4. Technical specifications	6
4.1. Physical and dimensional specifications	6
4.2. Power meter specifications	8
4.3. Electrical specifications	9
4.4. Environmental specifications	9
4.5. Glass refractive index	10
4.3. Patterns overview	11
4.4. Fluorescence spectral features	13
4.5. Suggested analyses	17
5. Description of the patterns	18
5.1. Field of rings (PAT-AG03-EM3-B3)	18
5.2. 4x4 intensity gradation (PAT-AG03-EM3-C3)	19
5.3. 3D crossing stairs (PAT-AG03-EM3-I9)	20
5.4. Repositioning crosses (PAT-AG03-EM3-H3)	21
5.5. Word ARGOLIGHT (PAT-AG03-EM3-J3)	21

5.6. Coordinates of each pattern	22
6. Operating the power meter	23
6.1. Sensor lateral alignment.....	23
6.2. Sensor axial alignment	24
6.3. Cable adjustment.....	25
6.4. Software interface.....	26
7. Calibration, accuracy and limitations	27
7.1. Calibration	27
7.2. Calibration accuracy and measurement uncertainty	27
7.3. Calibration limitations	27
8. Regulatory compliance.....	28
8.1. Product safety and electromagnetic compatibility	28
8.2. CE marking	28
8.3. FCC class B digital device or peripheral	28
8.4. WEEE directive.....	29

1. Introduction

The Argo-POWER^{LM} (Low Magnification) is specifically designed to assess and monitor the performance of fluorescence imaging systems, such as wide-field, confocal laser scanning or confocal spinning disk microscopes, with low magnifications.

The Argo-POWER^{LM} is not compatible with imaging modalities based on total internal reflection (TIRF), fluorophore localization (PALM, STORM, DNA-PAINT) and stimulated emission by depletion (STED).

This product is composed of:

- An optical power meter, based on a silicon photodiode, compatible with dry objectives.
- An Argo-LM glass, compatible with system magnifications ranging from 5 up to 20x, made of the third generation of Argoglass[®].
- A dedicated software, Daybook, to generate, track and export quality control data.

The optical power meter is designed to measure the optical power of laser light or other monochromatic or near monochromatic light sources at the sample plane in microscopy setups.

The Argo-LM glass consists of a special glass substrate with different fluorescent patterns embedded inside, designed to quality-control many aspects of a low magnification fluorescence imaging system, such as: field uniformity, field distortion, lateral co-registration accuracy, intensity response, stage drift during Z-stacking, etc.

The Daybook software has two modules:

- The “Analysis” module, named “Daybook Analysis”: it allows to analyze and extract data (maps, graphics and metrics) from images of the patterns, in order to measure significant metrics of low magnification fluorescence imaging system.
- The “Data Manager” module, named “Daybook Data Manager”: it allows to visualize the data generated by the “Analysis” module, monitor the results, and manage the quality control reports.

The best of Argolight technology, associated with an optical power meter, adapted into a microscope slide format, and combined with the Daybook software, opens the path to easy, yet reliable and complete, quality control of low magnification fluorescence imaging systems.

2. First use

2.1. Parcel verification

Inside the package, you will find:

- 1 Argo-POWER^{LM}.
- 1 control unit.
- 1 USB 2.0 Type-A to Mini-B cable.
- 1 storage suitcase.
- 1 user guide documentation.
- 1 certificate of inspection.

Before starting, check that all these items are present and check if the device has visible damages. If any damage is observed, please contact Argolight within one week (7 days) after delivery.

2.2. Quick start procedure

Step 1 – Software installation

- Download the Daybook software here: www.argolight.com/measure-microscopes-performances-detect-issues-with-daybook/
- Download the ARGO calibration file of the sensor here: www.argolight.com/knowledge-center/get-my-calibration-file-for-argo-power/
- Install Daybook on the computer that will be used to read the optical power measurements. The operating system must be a **64 bits Windows 7, 8 or 10** version.
- Plug the USB cable to the control unit and to the computer.
- Open Daybook Analysis. A settings panel will open.
- In the settings panel, choose “Argo-POWER^{LM}” in the “product type” list.
- In the settings panel, upload the ARGO calibration file and click “OK”.
- Click on the “Power meter” button on the top-left corner.
- After the connection between the device and the computer is established, enter the light source wavelength and the sampling period, and click on the “Power measurement” button.

Step 2 – Optical power measurements

- Select a microscope objective without immersion (dry objective).
- Set up the device in the microscope sample holder.
- Plug the cable from the power meter head to the control unit.

- Illuminate the sensor.
- Align the light beam with the sensor's center, using the XY translation stages.
- In Daybook Analysis, fill out the "Excitation wavelength" and the "Sampling period" boxes, and click on the "Run power measurement" button.
- Adjust the focus until the highest optical power is measured. This means the sensor is at the focal plane of the microscope objective.
- Start the optical power measurements.

Step 3 – Patterns imaging and analysis

- In your fluorescence imaging system, select a low magnification microscope objective, typically a 10× or 20×.
- Illuminate the glass with UV-blue light (preferably at a wavelength between 350 nm and 500 nm).
- Coarsely align the center of the field of view with the center of the glass, using the XY translation stages.
- Adjust the focus into the glass until clearly observing the fluorescent patterns through the eyepieces or camera(s).
- Move the slide to observe the pattern(s) of interest.
- Switch to your working microscope objective.
- Re-adjust, if necessary, the position of the pattern(s) and the focus in the glass. Once you are perfectly in focus and the pattern is centered with respect to the field of view, you can set to zero the X, Y and Z positions in the acquisition software, so that it will be easier to come back later to the pattern position.
- Start your imaging session.
- Save the image(s) of your pattern(s) of interest from your usual acquisition software.
- Run Daybook Analysis to get meaningful results.

To know how to image your pattern(s) of interest properly, please refer to our documentation, available within Daybook Analysis, or online on our website (www.argolight.com).

3. General handling and care

3.1. Handling and storage

Optical power meter

In order to make the optical power meter last for many years, we recommend that you observe the following handling and storage instructions:

- Do not put immersion liquids on the sensor.
- Do not shine more than 100 mW of average power on the sensor.
- Do not use with focused ultrashort pulsed lasers, like those used in multiphoton microscopy.
- Do not illuminate with irradiances (peak or average) larger than 100 MW.cm⁻².
- Do not drop out.
- Do not pull off the cables.
- Do not scratch the sensor surface.
- Do not push the sensor towards an objective.
- Do not expose to extreme temperature and humidity conditions.
- Store in its suitcase at ambient temperature (10 – 40 °C) and normal relative humidity (20 – 70 % RH).

Argo-LM glass

In order to make the Argo-LM glass last for many years, we recommend that you observe the following handling and storage instructions:

- The third generation of Argoglass® is compatible with any type of immersion medium (oil, water, glycerol and air). In the case of a water immersion, continuous exposure higher than 20 minutes in a row should be avoided. When longer continuous exposures are required, use oils with the same refractive index as water as an immersion liquid.
- Do not illuminate with focused ultrashort pulsed lasers, like those used in multiphoton microscopy.
- Do not illuminate with irradiances (peak or average) larger than 50 GW.cm⁻².
- Do not drop out.
- Do not scratch the glass surfaces.
- Do not push towards an objective.
- Do not expose to extreme temperature and humidity conditions.
- Store in its suitcase (after having removed entirely the immersion liquid) at ambient temperature (10 – 40 °C) and normal relative humidity (20 – 70 % RH). Avoid ultraviolet irradiation.

3.2. Cleaning

Optical power meter

To clean the sensor surface, we recommend that you observe the following cleaning instructions:

- Remove dust using clean compressed air.
- Use lint-free soft cotton swabs (or lens tissue) moistened with ethanol or isopropanol (alcohol degree higher than 90° for both), as one would do for any regular optical component. As water tightness is not 100 % guaranteed, the use of excessive liquid can infiltrate and damage the sensor.

Wearing gloves is advised. Do not use acetone.

Argo-LM glass

To clean the glass surfaces, we recommend that you observe the following cleaning instructions:

- Remove dust using clean compressed air.
- Use lens tissue moistened with ethanol or isopropanol (alcohol degree higher than 90° for both), as one would do for any regular optical component.

Wearing gloves is advised. Do not use acetone.

3.3. Operating environment

The Argo-POWER^{LM} has been designed to be used at room temperature (10 – 40 °C) and under normal relative humidity (20 – 70 % RH).

The change of the sensor response to temperature variations within the 10 – 40 °C range is negligible, so are the optical power measurements.

Both the glass and the aluminum slide composing the product have a low thermal expansion coefficient, so that temperature variations within the 10 – 40 °C range will not significantly affect the imaging of the patterns.

4. Technical specifications

4.1. Physical and dimensional specifications

The aluminum slide has the same format and dimensions as a standard microscope slide (75 mm × 25 mm), except for the thickness which is 6 mm, as shown in Figure 1.

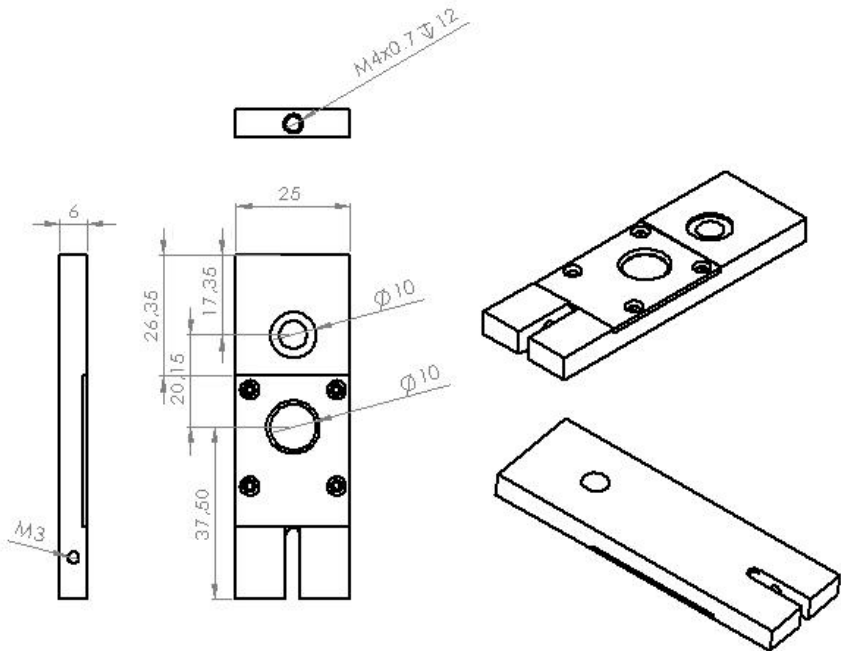

Figure 1: Scheme of the aluminum slide with dimensional specifications. All dimensions are in mm. General tolerances are ± 0.1 mm.

Table 1 presents the physical and dimensional specifications of the complete device

Head dimensions	l: (75.0 +0/-0.1) mm w: (25.0 +0/-0.1) mm t: (6.0 +0.1/-0) mm
Control unit dimensions	100.0 mm × 50.0 mm × 25.5 mm
Total weight	0.2 kg
Head cable length	1.50 m
USB cable length	1.83 m
Head-to-unit connector	FFA Male
PC-to-unit connector	USB 2.0 Type-A to Mini-B
Post mounting	Universal 8-32 / M4 Tap, Post not included

Table 1: Physical and dimensional specifications of the device.

4.2. Power meter specifications

Table 2 presents the technical specifications of the optical power meter.

Detector type	Silicon photodiode
Active detector area	10 mm diameter
Neutral density filter	Reflective (OD 2)
Input aperture	9 mm
Wavelength range	350 – 1100 nm
Power range	10 μ W – 100 mW
Linearity	$\pm 2 \%$
Resolution	< 3 μ W (350 – 400 nm) < 2 μ W (400 – 460 nm) < 1 μ W (460 – 1100 nm)
Calibration uncertainty	$\pm 10 \%$ maximum over the whole wavelength range Typically, $\pm 2 \%$ at 633 nm
Response time	100 ms (minimum), 3 s (to ensure stable reading)
Objective compatibility	Air coupled objectives, with FOV* diameters less than 9 mm

Table 2: Technical specifications of the optical power meter. *FOV = "Field Of View".

4.3. Electrical specifications

Table 3 presents the electrical specifications of the control unit.

Head-to-unit connector	FFA Male
PC-to-unit connector	USB 2.0 Type-A to Mini-B
Maximum supply voltage	5 V
Maximum supply current	500 mA
OS compatibility	Windows 7/8/10 64 bits

Table 3: Electrical specifications of the control unit.

4.4. Environmental specifications

Table 4 presents the environmental specifications of the optical power meter.

Operating conditions	
Ambient temperature	10 – 40 °C
Relative humidity	20 – 70 %
Atmospheric pressure	700 – 1060 hPa
Altitude	2000 m (maximum)
Transport and storage conditions	
Temperature	-10°C – 60 °C
Relative humidity	10 – 80 %
Atmospheric pressure	500 – 1060 hPa

Table 4: Environmental specifications for operation, transport and storage of the device.

4.5. Glass refractive index

The slide contains one piece of Argoglass[®], which is a special glass substrate produced at the Argolight facility to ensure homogeneity and purity.

The dispersion of the glass refractive index is shown in Figure 2. The measurement uncertainty is ± 0.001 . The Argoglass[®] features the same refractive index as microscope coverslips, defined in the ISO 8255-1:2017 standard.

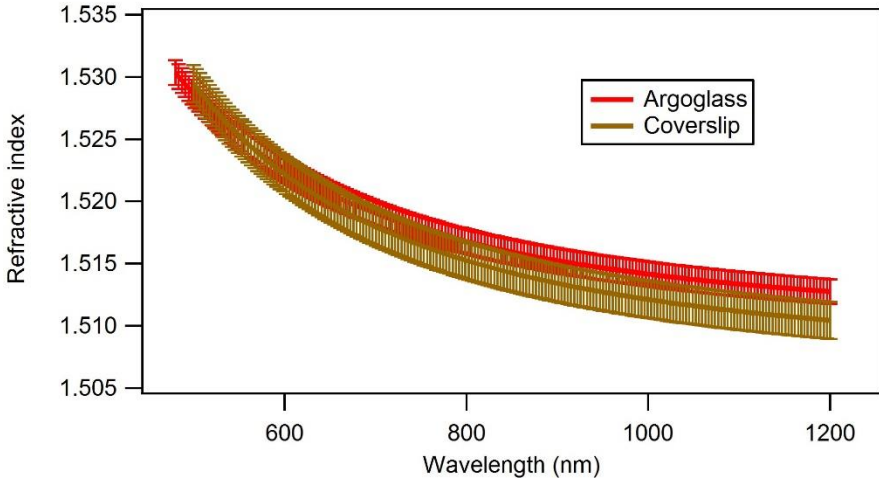

Figure 2: Dispersion of the refractive index of the Argoglass[®], compared to the one of microscope coverslips.

The Sellmeier equation for the glass refractive index dispersion is (λ in nm):

$$n^2(\lambda) = A + \frac{B\lambda^2}{\lambda^2 - C} + \frac{D\lambda^2}{\lambda^2 - E},$$

which coefficients are provided in Table 5.

Sellmeier coefficient	A	B	C	D	E
Value	0.699	0.697	136.960 nm ²	0.883	15269.000 nm ²

Table 5: Sellmeier coefficients for the refractive index dispersion of the Argoglass[®].

4.3. Patterns overview

The fluorescent patterns, depicted in Figure 3, are positioned $(170 \pm 5) \mu\text{m}$ below the top surface of the Argoglass[®], whose optical flatness is typically $0.065 \mu\text{m}$, on a plane whose parallelism with respect to the bottom surface of the aluminum slide is less than or equal to 5 mrad .

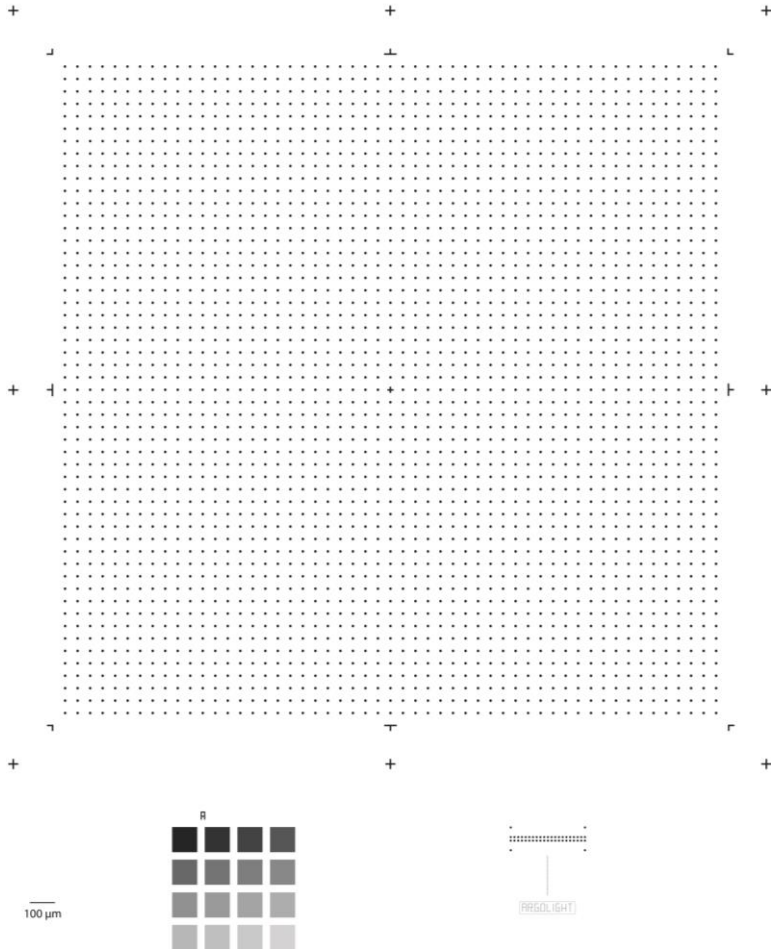

Figure 3: Schematics of the patterns inside the piece of glass of the slide. All dimensions are in μm .

These features emulate the presence of a #1.5H microscope coverslip, having a thickness of $(170 \pm 5) \mu\text{m}$ and a refractive index of (1.5255 ± 0.0015) at 546.1 nm.

The constituents within each individual pattern are positioned with a maximum relative error of $\pm 0.11 \mu\text{m}$ in XY and $\pm 0.15 \mu\text{m}$ in Z.

4.4. Fluorescence spectral features

The spectral features (excitation spectrum, emission spectrum and lifetime) of the patterns depend on the excitation and emission wavelengths, on the spatial scale at which they are measured, and on the illumination power density and duration.

Given the large range of possible irradiation conditions, Argolight only provides typical spectral features averaged on a scale of several micrometers, which are only valid for given excitation/emission conditions. Typical fluorescence spectral features are shown below.

- **Excitation**

The excitation ranges from 250 up to 650 nm. The excitation efficiency is maximum at around 340 nm and drops towards the red wavelengths. A typical absorption spectrum is shown in Figure 4.

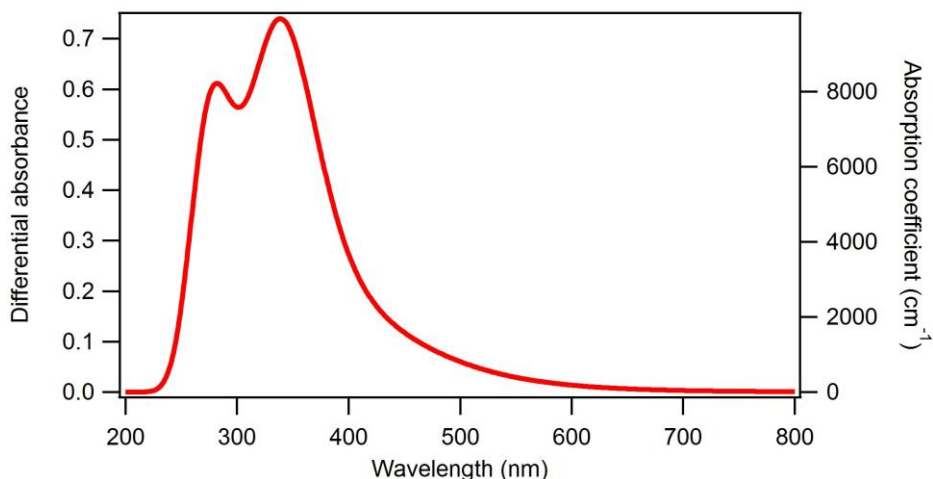

Figure 4: Typical absorbance/absorption spectrum of the patterns.

- **Emission**

The emission is a continuum starting from slightly above the excitation wavelength up to 800 nm. Typical emission spectra are shown in Figure 5 for UV-blue excitation wavelengths and in Figure 6 for visible excitation wavelengths.

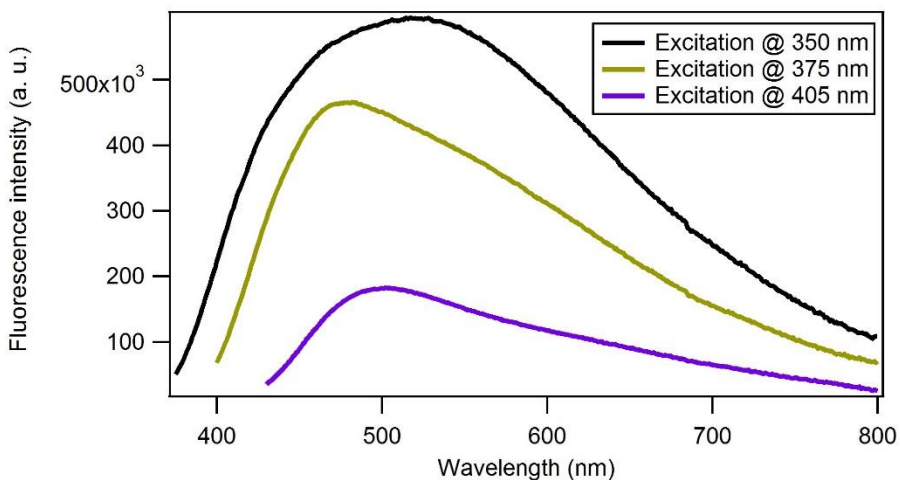

Figure 5: Typical emission spectra of the patterns for excitation wavelengths at 350 nm, 375 nm and 405 nm.

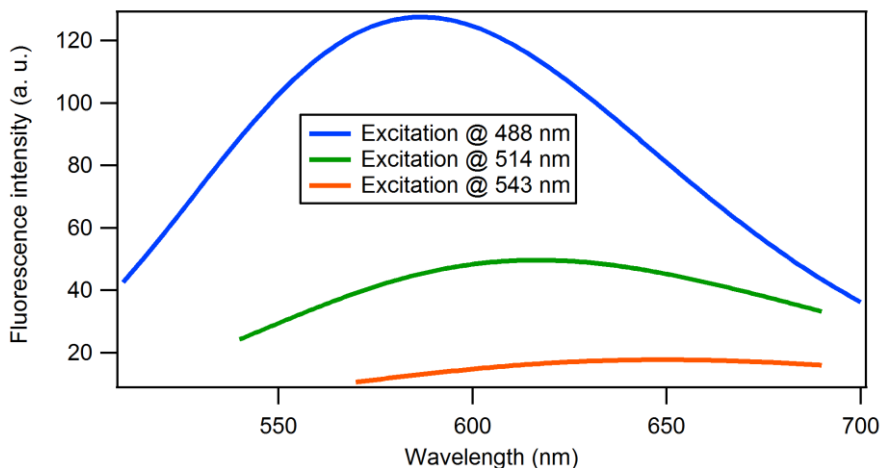

Figure 6: Typical emission spectra of the patterns for excitation wavelengths at 488 nm, 514 nm and 543 nm.

- **Lifetime**

Using FLIM (Fluorescence Lifetime Imaging Microscopy), two main decay components of (0.29 ± 0.05) ns and (2.52 ± 0.50) ns have been measured.

These values are provided for information and are not guaranteed. A typical fluorescence decay is shown in Figure 7.

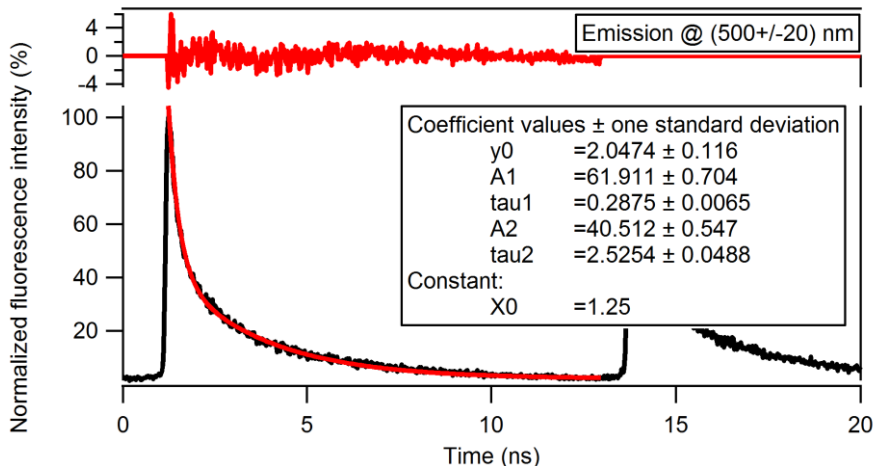

Figure 7: Typical fluorescence decay of the patterns for $\lambda_{\text{exc}} = 400 \text{ nm}$, $\Delta\lambda_{\text{em}} = (500 \pm 20) \text{ nm}$, $10\times/0.25$ objective.

- **Photo-stability**

The intensity of the patterns may decrease. However, this decrease is transient. The fluorescence intensity recovers to its initial value after some time. The recovery time, *i.e.* the time it takes to the fluorescence intensity to get back to its initial value, depends on the irradiation conditions (power density, illumination duration, excitation and emission wavelengths, zoom, etc.). The recovery time can be from seconds to months, with typical values in the minutes range. A typical fluorescence intensity recovery signal is shown in Figure 8.

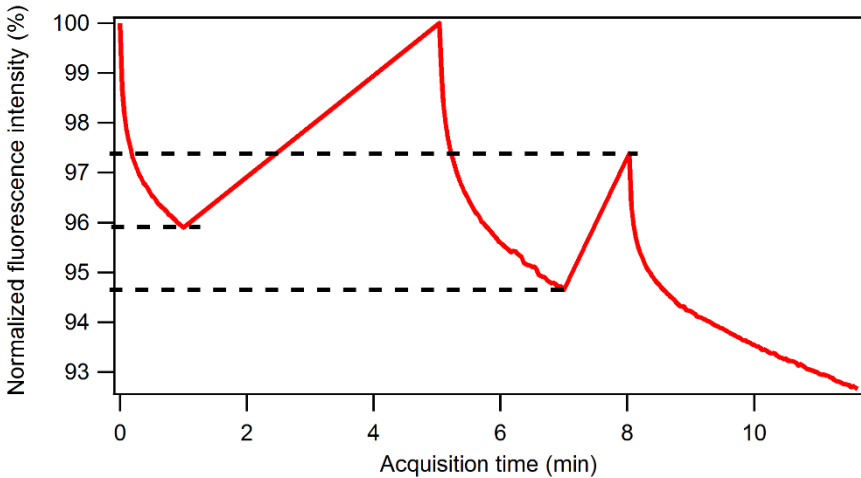

Figure 8: Typical fluorescence intensity recovery signal of the patterns. The power density was about 10 W.cm^{-2} , the excitation wavelength was $(470 \pm 20) \text{ nm}$ and the collection window was $(525 \pm 25) \text{ nm}$. After one minute of acquisition and four minutes of waiting time, the fluorescence fully recovers for these irradiation conditions. When the waiting time is not sufficient, the fluorescence intensity does not restart at its original level.



Proceed with caution!

The field or rings (section 5.1) and the 4x4 intensity gradation (section 5.2) are patterns for which fluorescence intensity is important. They must therefore be imaged with a lot of care:

- First, move to a pattern for which intensity is not important, such as a cross or the word ARGOLIGHT.
- Second, set all the acquisition parameters (illumination power, sensor gain, exposure time, etc.) for one of these patterns.
- Third, move to the pattern of interest (field of rings or 4x4 intensity gradation) and image it in one shot.

Do not image one of these patterns using a tiles acquisition mode.

By following this procedure, the transient fluorescence decay has barely the time to occur, making the recovery time much faster. This procedure allows a more frequent imaging.

4.5. Suggested analyses

Table 6 presents the analyses that can be performed with Daybook Analysis from images of the patterns in the Argo-POWER^{LM}. Note that this table is only valid for the Argo-POWER^{LM}, at the date of issue of this document. To know the up-to-date correspondence between the patterns and analyses, please refer to the “Start guide”, available directly under the “Help” menu of Daybook Analysis.

Pattern name	Associated analysis
Field of rings	Field uniformity Field distortion Lateral co-registration accuracy Line spread function Ring spread function
4×4 intensity gradation	Intensity response
3D crossing stairs	Stage drift during Z-stacking
Repositioning crosses	Stage repositioning repeatability Stage drift during timelapse
Word ARGOLIGHT	Spectral response

Table 6: Pattern and analysis correspondence in Daybook Analysis.

5. Description of the patterns

To know more about the functions and applications of each pattern, you can consult the “Applications guide”, available on the Argolight website: www.argolight.com/files/Argolight-solutions_Applications-guide.pdf

Documentations describing how to acquire images of these patterns and how to analyze them are available directly under the “Help” menu of Daybook Analysis.

5.1. Field of rings (PAT-AG03-EM3-B3)

This pattern, depicted in Figure 9, consists of a matrix of 53×53 rings, separated by 50 μm, on a total field of 2600 μm × 2600 μm. The field of rings is surrounded by eight landmarks and exhibits a 25 μm long cross in its center.

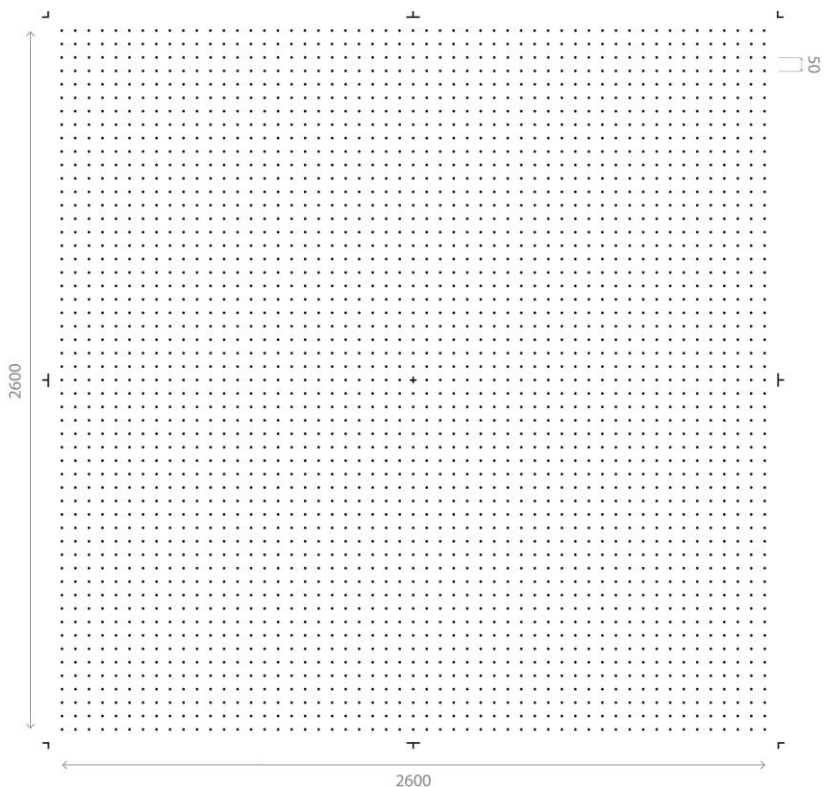

Figure 9: Schematics of the field of rings. All dimensions are in μm.

The typical transverse diameter (in the XY plane) of those rings is about $(1.8 \pm 0.3) \mu\text{m}$.

The typical axial length (in the Z direction) of those rings is about $(12.0 \pm 3.0) \mu\text{m}$ FWHM (Full Width at Half Maximum).

5.2. 4x4 intensity gradation (PAT-AG03-EM3-C3)

This pattern, depicted in Figure 10, consists of two layers of sixteen $100 \mu\text{m}$ -wide squares, on top of each other, having different fluorescence intensity levels following a linear evolution, organized in a 4x4 matrix.

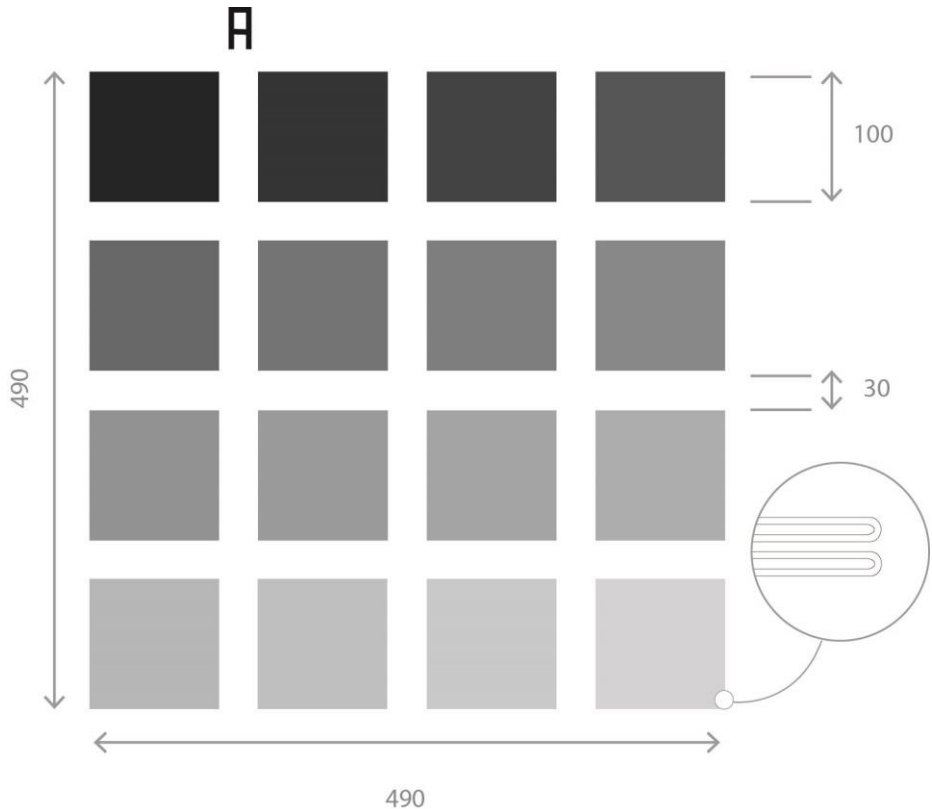

Figure 10: Schematics of the 4x4 intensity gradation. All dimensions are in μm .

5.3. 3D crossing stairs (PAT-AG03-EM3-I9)

This pattern, depicted in the Figure 11, consists of twice 21 empty cylinders embedded at different depths, like two crossing stairs, with a step of 2.5 μm and surrounded by four pillars.

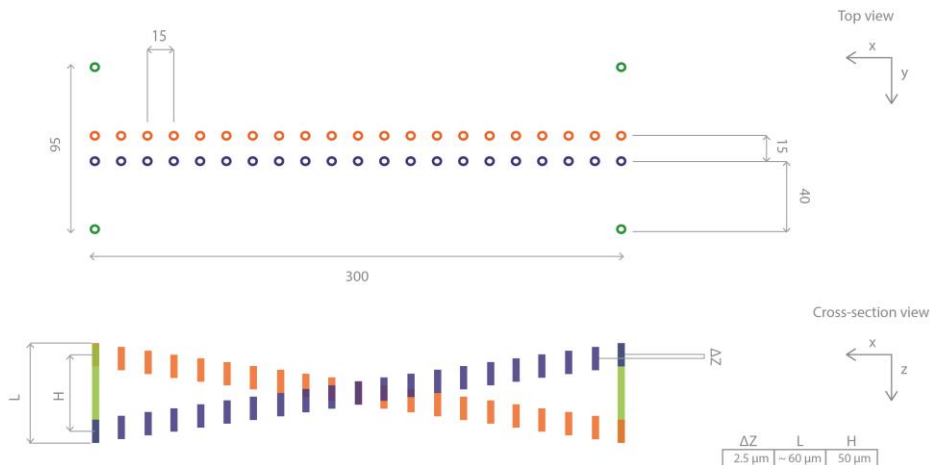

Figure 11: Schematics of the 3D crossing stairs. All dimensions are in μm .



Warning!

Depending on the objective used to image (Z-stacking) the 3D crossing stairs, the measured axial distances may be distorted, and shall therefore be corrected to be compared to the specified axial distances:

- For dry objectives, designed for use with a #1.5H coverslip, there is no correction factor to apply to the measured axial distances.
- For immersion objectives, designed for use with a #1.5H coverslip, the measured axial distances shall be divided by the refractive index of the immersion medium (for example: water \rightarrow 1.333, glycerol \rightarrow 1.475, regular oil \rightarrow 1.518).

The warning applies to the Argo-LM only. The correction factor may change from one Argolight product to another.

5.4. Repositioning crosses (PAT-AG03-EM3-H3)

The repositioning crosses, depicted in Figure 12, are 40 μm long and are positioned 1500 μm from one to another in the X direction, the Y direction, or both.

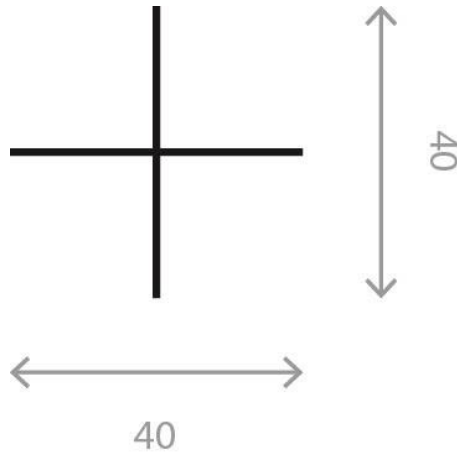

Figure 12: Schematics of one of the repositioning crosses. All dimensions are in μm .

5.5. Word ARGOLIGHT (PAT-AG03-EM3-J3)

This pattern, depicted in Figure 13, consists of the letters forming the company name “Argolight”, and surrounded by a 220 μm \times 50 μm frame.



Figure 13: Schematics of the word ARGOLIGHT. All dimensions are in μm .

5.6. Coordinates of each pattern

Table 7 presents the XY coordinates, relative to the central cross of the field of rings, of the center of each pattern, in order to help for the automation of the image acquisition.

Pattern name	Relative coordinates (X ; Y) in μm
Center of the field of rings	(0 ; 0)
4x4 intensity gradation	(-625 ; -1995)
3D crossing stairs	(625 ; -1772.5)
Word ARGOLIGHT	(625 ; -2075)

Table 7: XY coordinates of the center of each pattern relative to the central cross of the field of rings.

6. Operating the power meter

6.1. Sensor lateral alignment

The sensor is compatible with any upright or inverted microscopes but can also be used in an experimental setup on an optical table.

For upright microscopes, the alignment is easy as you can see simultaneously with your eyes both the light beam and the sensor (*cf.* Figure 14). Align the sensor's center to the light beam, using the XY translation stage.



Figure 14: Argo-POWER^{LM} head inserted in the sample holder of an upright microscope; the sensor is illuminated with blue light, at its center.

For inverted microscopes, use the target etched at the back of Argo-POWER^{LM} head, on the opposite side of the sensor. Align the target's center to the white light coming out from the condenser (*cf.* Figure 15). This approach assumes that the white light coming out from the condenser and the light beam coming out from the objective are roughly co-aligned.



Figure 15: Argo-POWER^{LM} head inserted in the sample holder of an inverted microscope; the target, on the opposite side of the sensor, is illuminated with the white light coming out from the condenser.

The sensor can also be used like a “traditional” power meter, to measure the optical power of a collimated (or slightly converging / diverging) light beam (*cf.* Figure 16).



Figure 16: Argo-POWER^{LM} head inserted across the optical path of a collimated light beam.

6.2. Sensor axial alignment

When the Argo-POWER^{LM} is used with microscopes, adjust the focus until the highest optical power is measured to find the best axial position. This indicates that the sensor is at the focal plane of the microscope objective.

In a widefield microscopy configuration, the light is focused onto the objective and more or less collimated (depending on the objective magnification) onto the sample afterwards. For that reason, in widefield mode, not being at the focal plane (to some extent) has little effect on the power measurement.

In a confocal microscopy configuration, the light is collimated onto the objective and more or less focused (depending on the objective numerical aperture) onto the sample afterwards. Therefore, in confocal mode, being far from the focal plane has a huge impact on the power measurement, as a non-negligible fraction of the beam may not reach the sensor, due to its high divergence.

6.3. Cable adjustment

If the microscope configuration prevents the cable from positioning correctly the Argo-POWER^{LM} inside the slide holder, it is possible to hold the cable by screwing the M3 screw located on one of the edges (cf. Figure 17).

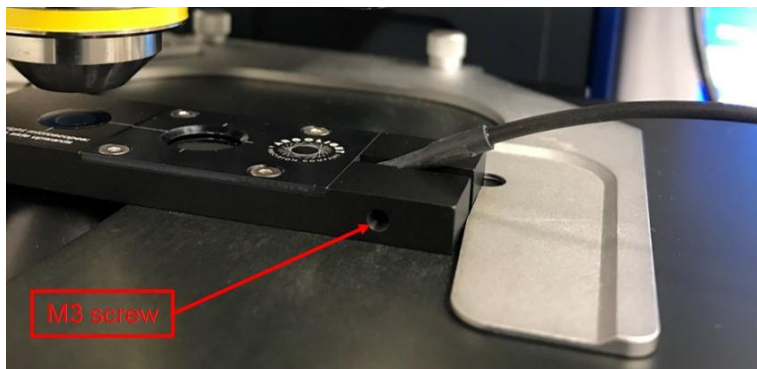

Figure 17: Cable of the Argo-POWER^{LM} held thanks to the M3 screw.

6.4. Software interface

A complete documentation describing the power meter software interface and the related frequently asked questions is available directly under the “Help” menu of Daybook Analysis, “Power meter” documentation (cf. Figure 18).



Figure 18: Finding the “Power meter” documentation in Daybook Analysis.

7. Calibration, accuracy and limitations

7.1. Calibration

The power meter is calibrated by Argolight prior to shipping. An ARGO calibration file is provided, which must be uploaded into the Daybook Analysis software on the first time the power meter is used. An Argolight certificate of calibration is provided with the product.

The power meter response can change or deteriorate with time, especially if it has been illuminated with excessive average and/or peak power. Argolight advises to recalibrate the power meter every 12 months to ensure accuracy in the measurements.

7.2. Calibration accuracy and measurement uncertainty

Argolight calibrates its power meters using secondary standards directly traceable to LNE (Laboratoire national de métrologie et d'essais, the official French metrology institute). The measurement uncertainty of the power meter is claimed to be $\pm 10\%$, with $k = 2$. This means there is a 95 % probability the reported measurement from the power meter falls within $\pm 10\%$ of the LNE reference detector standard.

The given uncertainty contains all possible contributions to the measurement error: the calibration accuracy, the non-uniformity of the detector response over its surface, and the light reflections from the components of the sensor.

7.3. Calibration limitations

The calibration stands as long as the power meter is operated within the environmental specifications (see section Environmental specifications), within the optical power range (10 μW – 100 mW), and within the linear region of the sensor response.

Special care should be taken when ***non-focused*** laser pulses are shined onto the sensor. Especially with laser pulses, saturation effects may occur, depending upon wavelength, peak power, pulse shape, pulse duration, repetition rate.

8. Regulatory compliance

8.1. Product safety and electromagnetic compatibility

The Argo-POWER^{LM} devices have been tested and found to comply with product safety and electromagnetic compatibility requirements. For a complete list of tests and for certification details, please contact your Argolight representative.

8.2. CE marking

The “CE” logo (see on the below) etched on the control unit indicates that this equipment complies with the following directives:

- | | |
|--|--|
| <ul style="list-style-type: none">• Council Directive 2014/35/EU Low Voltage Directive• Council Directive 2014/30/ECU EMC Directive• Council Directive 2012/19/EU WEEE Directive• Council Directive 2011/65/EU RoHS |  |
|--|--|



8.3. FCC class B digital device or peripheral

Note: This equipment has been tested and found to comply with the limits for a Class B digital device, pursuant to Part 15 of the FCC Rules. These limits are designed to provide reasonable protection against harmful interference when the equipment is operated in a residential installation. This equipment generates, uses and can radiate radio frequency energy and, if not installed and used in accordance with the instruction manual, may cause harmful interference to radio communications. However, there is no guarantee that interference will not occur in a particular installation. If this equipment does cause harmful interference to radio or television reception, which can be determined by turning the equipment off and on, the user is encouraged to try to correct the interference by one or more of the following measures:

- Reorient or relocate the receiving antenna.
- Increase the separation between the equipment and receiver.
- Connect the equipment into an outlet on a circuit different from that to which the receiver is connected.
- Consult the dealer or an experienced radio/TV technician for help.

Warning: Changes or modifications not expressly approved by Argolight could void the user’s authority to operate the equipment.

8.4. WEEE directive

The “crossed out bin” logo (see below) etched in the control unit indicates that this product should not be disposed of along with municipal waste, that the product should be collected separately, and that a separate collection system exists for all products that contain this symbol within member states of the European Union.

As required by the WEE (Waste Electrical and Electronic Equipment Directive) of the European Union (EU) and the corresponding national laws, Argolight offers all end users in the EU the possibility to return “end of life” Argo-POWER^{LM} devices without incurring disposal charges.

This offer is valid for Argo-POWER^{LM} devices from Argolight:

- Sold after June 1st of 2021.
- Sold to a company or institute within the EU.
- Currently owned by a company or institute within the EU.
- Still complete, not disassembled and not contaminated.



If you wish to return an Argo-POWER^{LM} for waste recovery, please contact Argolight or your nearest distributor for further information.

If you do not return an “end of life” Argo-POWER^{LM} to Argolight, you must hand it to a company specialized in waste recovery. **Do not dispose the device in a litter bin or at a public waste disposal site.**

Date of issue: 01/10/2021 (1st October 2021)

User guide version: v1.0

Product name and version: Argo-POWER^{LM} v2.0

Copyright notice

Copyright 2021 by Argolight SA. All rights reserved. No part of this book may be used or reproduced in any form or stored in a database or retrieval system. Making copies of any part of this book for any purpose other than your own personal use is a violation of European copyright laws.

Contact information

Argolight SA
Cité de la Photonique, Bdg. Elnath
11 avenue de Canteranne
33600 Pessac
France
Tel: (+33) 5 64 31 08 50
Website: www.argolight.com
Support: customer@argolight.com

Note for readers

The experimental data shown in this documentation are informative and not contractual. They may be different from one system to another.



A word about waste management

Argolight policy is to offer robust and reliable products that last. In the event your product becomes useless to you, please contact us so we can pick it up and recycle it. Please do not throw away the slide with common waste. The composition of the glass requires specific recycling. Thank you.

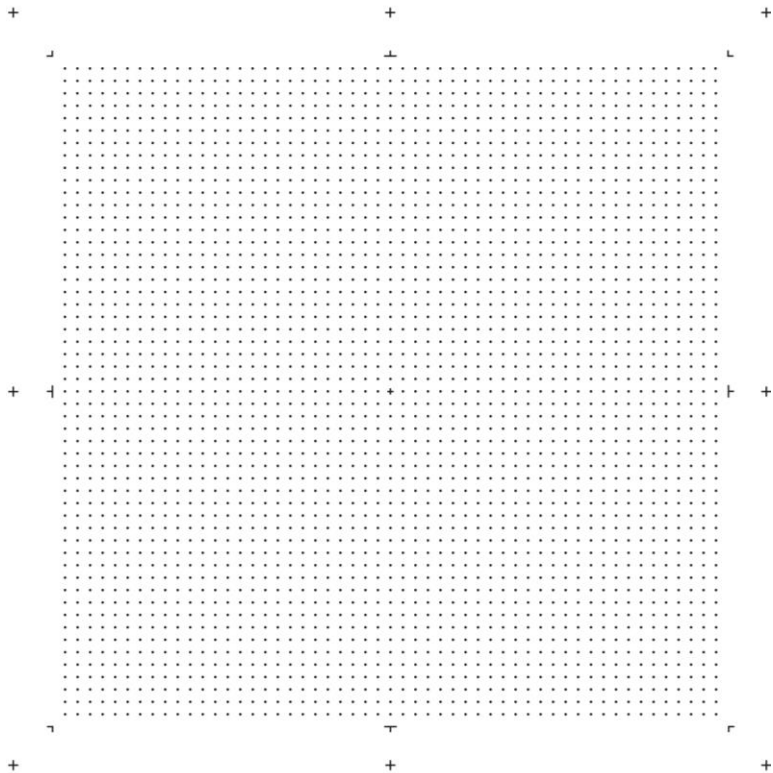

100 μ m

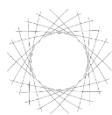
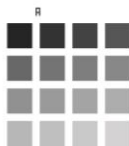

ARGOLIGHT
A Precision Company