

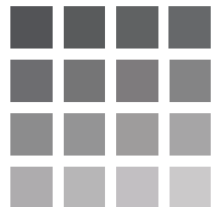

# USER GUIDE

## Argo-SIM

v2.0





# Table of contents

<b>1. Introduction</b>	<b>1</b>
<b>2. First use</b>	<b>2</b>
2.1. Parcel verification	2
2.2. Quick start procedure	2
<b>3. General handling and care</b>	<b>4</b>
3.1. Handling and storage	4
3.2. Cleaning	4
3.3. Operating environment	4
<b>4. Technical specifications</b>	<b>6</b>
4.1. Physical and dimensional specifications	6
4.2. Glass refractive index	7
4.3. Patterns overview	8
4.4. Fluorescence spectral features	10
4.5. Suggested analyses	14
<b>5. Description of the patterns</b>	<b>15</b>
5.1. Target (PAT-AG03-EM2-A2)	15
5.2. Field of rings (PAT-AG03-EM2-B2)	16
5.3. 4×4 intensity gradation (PAT-AG03-EM2-C2)	17
5.4. 2×16 intensity gradation (PAT-AG03-EM2-D2)	17
5.5. Gradually spaced lines (PAT-AG03-EM2-E5, -E6, -E7, -E8)	18
5.6. Matrix of crosses (PAT-AG03-EM2-F2)	19
5.7. Sphere (PAT-AG03-EM2-G2)	20
5.8. 3D crossing stairs (PAT-AG03-EM2-I5, -I6, -I7, -I8)	21

5.9. Repositioning crosses (PAT-AG03-EM2-H2) .....	22
5.10. Word ARGOLIGHT (PAT-AG03-EM2-J2) .....	23
5.11. 3D matrix of rings (PAT-AG03-EM2-K1) .....	23
5.12. Field of rings on a background (PAT-AG03-EM2-L1) .....	24
5.13. Geometrical figures (PAT-AG03-EM2-M1, -M2, -M3, -M4, -M5, -M6, -M7, -M8) .....	24
5.14. Grid (PAT-AG03-EM2-N1).....	25
5.15. Coordinates of each pattern .....	26

## 1. Introduction

The Argo-SIM (Structured Illumination Microscopy) is specifically designed to assess and monitor the performance of fluorescence imaging systems based on structured illumination, and/or deconvolution algorithms: interference-based SIM (for example 2D SIM and 3D SIM), single point-scanning SIM (for example Re-scan and Airyscan) and multi-point scanning SIM (for example instant SIM, or iSIM). The Argo-SIM is compatible with typical system magnifications of 40x-100x. It contains the third generation of Argoglass®.

The Argo-SIM is not compatible with imaging modalities based on total internal reflection (TIRF), fluorophore localization (PALM, STORM, DNA-PAINT) and stimulated emission by depletion (STED).

This product is composed of:

- An aluminum slide that includes one piece of Argoglass® with embedded fluorescent patterns inside.
- A dedicated software, Daybook, to generate, track and export quality control data.

The piece of Argoglass® consists of a special glass substrate with different fluorescent patterns embedded inside. The Argo-SIM is designed to quality-control many aspects of a structured illumination fluorescence imaging system, such as: field uniformity, field distortion, lateral co-registration accuracy, lateral resolution, intensity response, stage drift during Z-stacking, etc.

The Daybook software has two modules:

- The “Analysis” module, named “Daybook Analysis”: it allows to analyze and extract data (maps, graphics and metrics) from images of the patterns, in order to measure significant metrics of structured illumination fluorescence imaging system.
- The “Data Manager” module, named “Daybook Data Manager”: it allows to visualize the data generated by the “Analysis” module, monitor the results, and manage the quality control reports.

The best of Argolight technology, adapted into a microscope slide format, combined with the Daybook software, opens the path to easy, yet reliable and complete, quality control of structured illumination fluorescence imaging systems.

## 2. First use

### 2.1. Parcel verification

Inside the package, you will find:

- 1 Argo-SIM.
- 1 storage box.
- 1 user guide documentation.
- 1 certificate of inspection.

Before starting, check that all these items are present and check if the Argo-SIM has visible damages. If any damage is observed, please contact Argolight within one week (7 days) after delivery.

### 2.2. Quick start procedure

In order to quickly find and capture images of fluorescent patterns, we advise to follow the following steps:

- In your fluorescence imaging system, select a low magnification microscope objective, typically a 10x or 20x.
- Illuminate the glass with UV-blue light (preferably at a wavelength between 350 nm and 500 nm).
- Coarsely align the center of the field of view with the center of the glass, using the XY translation stages.
- Adjust the focus into the glass until clearly observing the fluorescent patterns through the eyepieces or camera(s).
- Move the slide to observe the pattern(s) of interest.
- Switch to your working microscope objective.
- Re-adjust, if necessary, the position of the pattern(s) and the focus in the glass. Once you are perfectly in focus and the pattern is centered with respect to the field of view, you can set to zero the X, Y and Z positions in the acquisition software, so that it will be easier to come back later to the pattern position.
- Start your imaging session.
- Save the image(s) of your pattern(s) of interest from your usual acquisition software.
- Run Daybook “Analysis” to get meaningful results.

To know how to image your pattern(s) of interest properly, please refer to our documentation, available Daybook Analysis, or online on our website ([www.argolight.com](http://www.argolight.com)).

## 3. General handling and care

### 3.1. Handling and storage

In order to make the Argo-SIM last for many years, we recommend that you observe the following handling and storage instructions:

- The third generation of Argoglass® is compatible with any type of immersion medium (oil, water, glycerol and air). In the case of a water immersion, continuous exposure higher than 20 minutes in a row should be avoided. When longer continuous exposures are required, use oils with the same refractive index as water as an immersion liquid.
- Do not illuminate with focused ultrashort pulsed lasers, like those used in multiphoton microscopy.
- Do not illuminate with irradiances (peak or average) larger than 50 GW.cm<sup>-2</sup>.
- Do not drop out.
- Do not scratch the glass surfaces.
- Do not push towards an objective.
- Do not expose to extreme temperature and humidity conditions.
- Store in its suitcase (after having removed entirely the immersion liquid) at ambient temperature (10 – 40 °C) and normal relative humidity (20 – 70 % RH). Avoid ultraviolet irradiation.

### 3.2. Cleaning

To clean the glass surfaces, we recommend that you observe the following cleaning instructions:

- Remove dust using clean compressed air.
- Use lens tissue moistened with ethanol or isopropanol (alcohol degree higher than 90° for both), as one would do for any regular optical component.

Wearing gloves is advised. Do not use acetone.

### 3.3. Operating environment

The Argo-SIM has been designed to be used at room temperature (10 – 40 °C) and under normal relative humidity (20 – 70 % RH). Both the glass and the aluminum slide composing the Argo-SIM have a low thermal expansion

coefficient, so that temperature variations will not significantly affect the imaging of the patterns.

## 4. Technical specifications

### 4.1. Physical and dimensional specifications

The aluminum slide has the same format and dimensions as a standard microscope slide (75 mm × 25 mm), except for the thickness which is 1.5 mm (to satisfy the required rigidity for this kind of tool), as shown in Figure 1. The weight of the Argo-SIM is approximately 8 g.

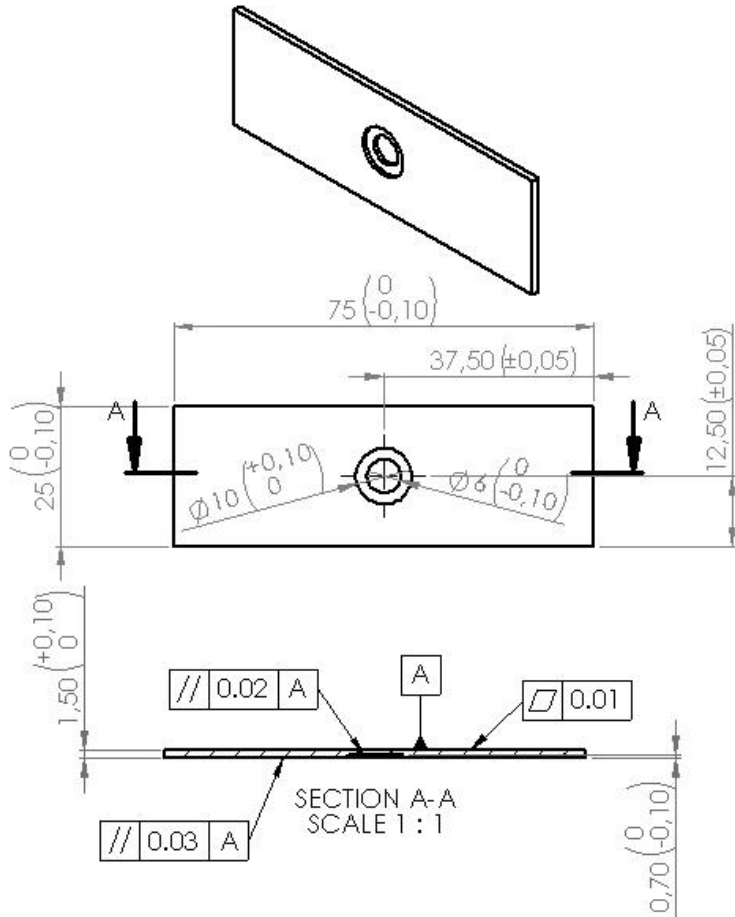
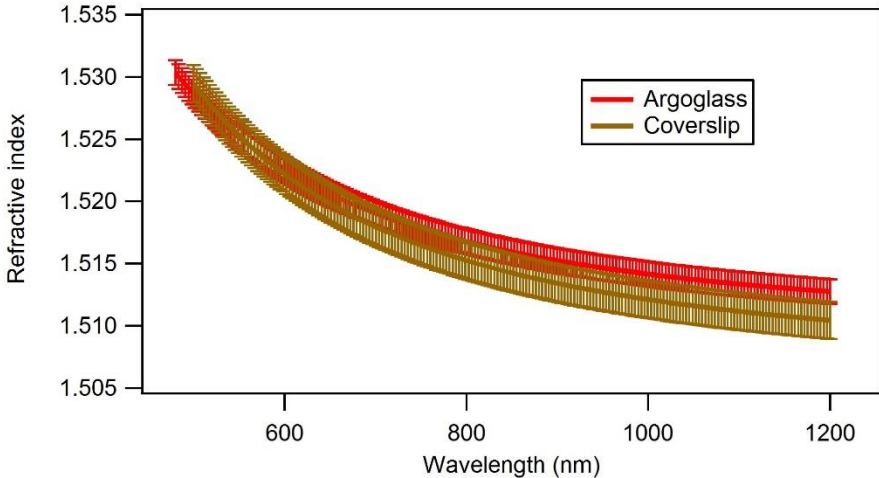

**Figure 1:** Scheme of the aluminum slide with dimensional specifications. All dimensions are in mm. General tolerances are  $\pm 0.1$  mm.

## 4.2. Glass refractive index

The slide contains one piece of Argoglass<sup>®</sup>, which is a special glass substrate produced at the Argolight facility to ensure homogeneity and purity.

The dispersion of the glass refractive index is shown in Figure 2. The measurement uncertainty is  $\pm 0.001$ . The Argoglass<sup>®</sup> features the same refractive index as microscope coverslips, defined in the ISO 8255-1:2017 standard.



**Figure 2:** Dispersion of the refractive index of the Argoglass<sup>®</sup>, compared to the one of microscope coverslips.

The Sellmeier equation for the glass refractive index dispersion is ( $\lambda$  in nm):

$$n^2(\lambda) = A + \frac{B\lambda^2}{\lambda^2 - C} + \frac{D\lambda^2}{\lambda^2 - E}, \text{ which coefficients are provided in Table 1.}$$

Sellmeier coefficient	A	B	C	D	E
Value	0.699	0.697	136.960 nm <sup>2</sup>	0.883	15269.000 nm <sup>2</sup>

**Table 1:** Sellmeier coefficients for the refractive index dispersion of the Argoglass<sup>®</sup>.

### 4.3. Patterns overview

The fluorescent patterns, depicted in Figure 3, are positioned  $(170 \pm 5) \mu\text{m}$  below the top surface of the Argoglass<sup>®</sup>, whose optical flatness is typically  $0.065 \mu\text{m}$ , on a plane whose parallelism with respect to the bottom surface of the aluminum slide is less than or equal to  $5 \text{ mrad}$ .

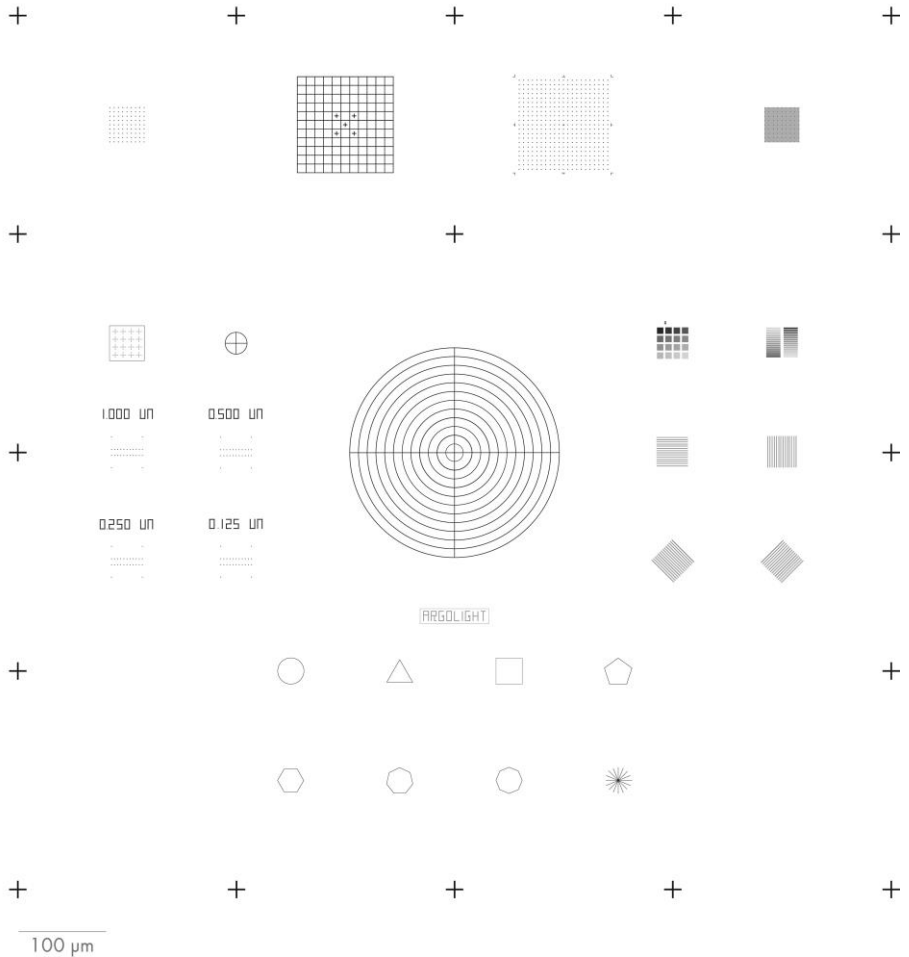

**Figure 3:** Schematics of the patterns inside the piece of glass of the slide. All dimensions are in  $\mu\text{m}$ .

These features emulate the presence of a #1.5H microscope coverslip, having a thickness of  $(170 \pm 5) \mu\text{m}$  and a refractive index of  $(1.5255 \pm 0.0015)$  at 546.1 nm.

The constituents within each individual pattern are positioned with a maximum relative error of  $\pm 0.11 \mu\text{m}$  in XY and  $\pm 0.15 \mu\text{m}$  in Z.

## 4.4. Fluorescence spectral features

The spectral features (excitation spectrum, emission spectrum and lifetime) of the patterns depend on the excitation and emission wavelengths, on the spatial scale at which they are measured, and on the illumination power density and duration.

Given the large range of possible irradiation conditions, Argolight only provides typical spectral features averaged on a scale of several micrometers, which are only valid for given excitation/emission conditions. Typical fluorescence spectral features are shown below.

- **Excitation**

The excitation ranges from 250 up to 650 nm. The excitation efficiency is maximum at around 340 nm and drops towards the red wavelengths. A typical absorption spectrum is shown in Figure 4.

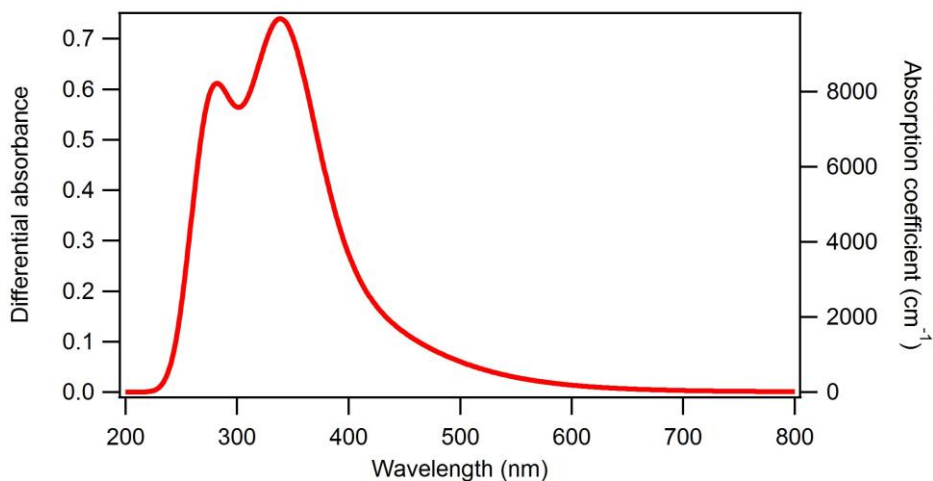

**Figure 4:** Typical absorbance/absorption spectrum of the patterns.

- **Emission**

The emission is a continuum starting from slightly above the excitation wavelength up to 800 nm. Typical emission spectra are shown in Figure 5 for UV-blue excitation wavelengths and in Figure 6 for visible excitation wavelengths.

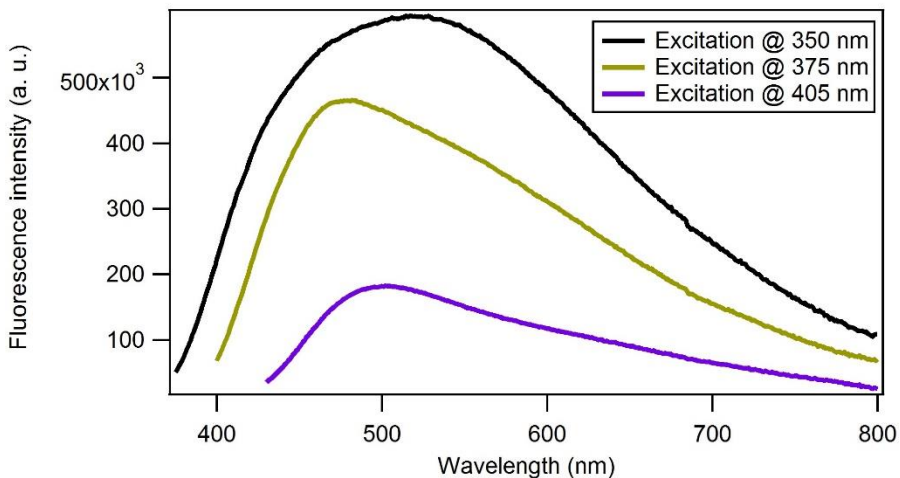

**Figure 5:** Typical emission spectra of the patterns for excitation wavelengths at 350 nm, 375 nm and 405 nm.

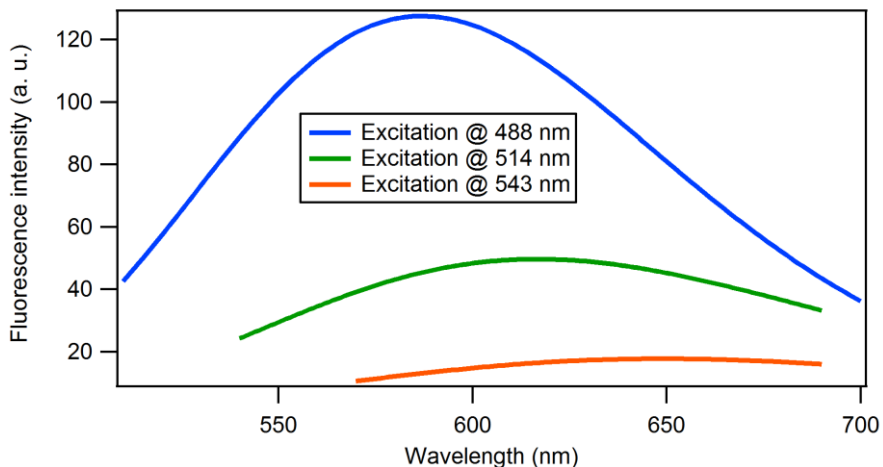
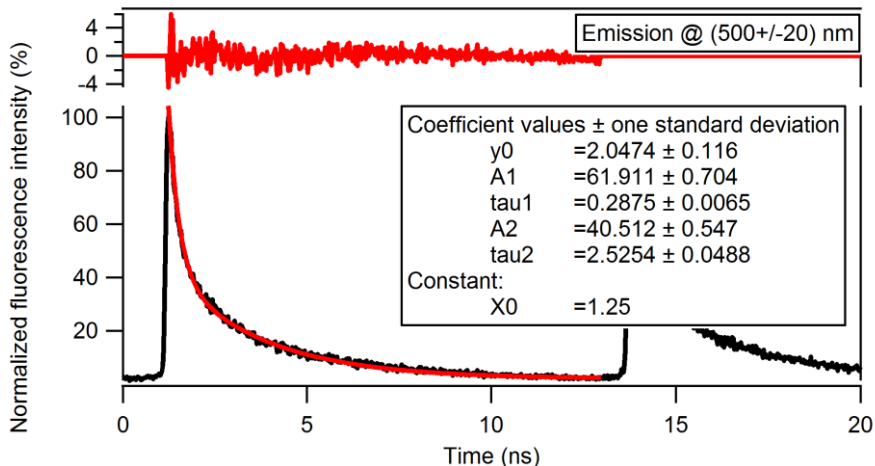

**Figure 6:** Typical emission spectra of the patterns for excitation wavelengths at 488 nm, 514 nm and 543 nm.

- **Lifetime**

Using FLIM (Fluorescence Lifetime Imaging Microscopy), two main decay components of  $(0.29 \pm 0.05)$  ns and  $(2.52 \pm 0.50)$  ns have been measured.

These values are provided for information and are not guaranteed. A typical fluorescence decay is shown in Figure 7.



**Figure 7:** Typical fluorescence decay of the patterns for  $\lambda_{exc} = 400$  nm,  $\Delta\lambda_{em} = (500 \pm 20)$  nm,  $10\times/0.25$  objective.

- **Photo-stability**

The intensity of the patterns may decrease. However, this decrease is transient. The fluorescence intensity recovers to its initial value after some time. The recovery time, *i.e.* the time it takes to the fluorescence intensity to get back to its initial value, depends on the irradiation conditions (power density, illumination duration, excitation and emission wavelengths, zoom, etc.). The recovery time can be from seconds to months, with typical values in the minutes range. A typical fluorescence intensity recovery signal is shown in Figure 8.

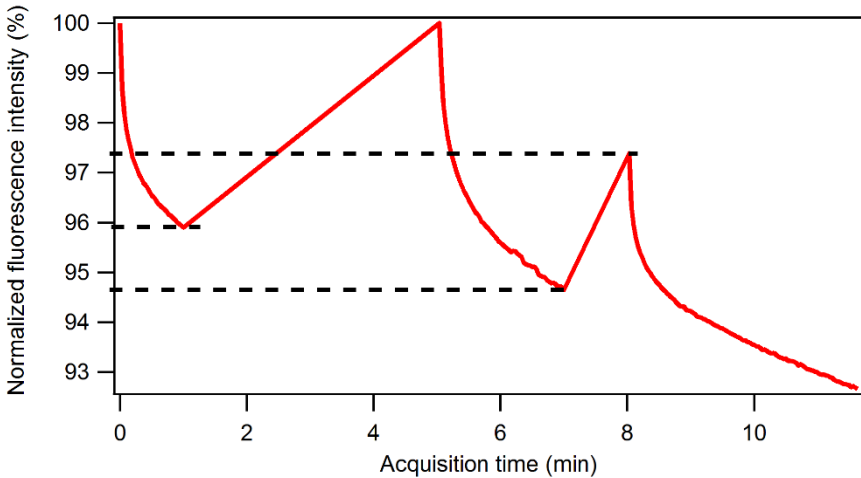

**Figure 8:** Typical fluorescence intensity recovery signal of the patterns. The power density was about  $10 \text{ W.cm}^{-2}$ , the excitation wavelength was  $(470 \pm 20) \text{ nm}$  and the collection window was  $(525 \pm 25) \text{ nm}$ . After one minute of acquisition and four minutes of waiting time, the fluorescence fully recovers for these irradiation conditions. When the waiting time is not sufficient, the fluorescence intensity does not restart at its original level.



**Proceed with caution!**

The field or rings (section 5.2), the  $4 \times 4$  intensity gradation (section 5.3) and the  $2 \times 16$  intensity gradation (section 5.4) are patterns for which fluorescence intensity is important. They must therefore be imaged with a lot of care:

- First, move to a pattern for which intensity is not important, such as a cross or the word ARGOLIGHT.
- Second, set all the acquisition parameters (illumination power, sensor gain, exposure time, etc.) for one of these patterns.
- Third, move to the pattern of interest (field of rings or  $4 \times 4$  intensity gradation) and image it in one shot.

**Do not image one of these patterns using a tiles acquisition mode.**

By following this procedure, the transient fluorescence decay has barely the time to occur, making the recovery time much faster. This procedure allows a more frequent imaging.

## 4.5. Suggested analyses

Table 2 presents the analyses that can be performed with Daybook Analysis from images of the patterns in the Argo-SIM. Note that this table is only valid for the Argo-SIM, at the date of issue of this document. To know the up-to-date correspondence between the patterns and analyses, please refer to the “Start guide”, available directly under the “Help” menu of Daybook Analysis.

<b>Pattern name</b>	<b>Associated analysis</b>
Target	Spectral response
Field of rings	Field uniformity Field distortion Lateral co-registration accuracy Line spread function Ring spread function
4×4 intensity gradation	Intensity response
2×16 intensity gradation	Intensity response
Gradually spaced lines	Lateral resolution
Matrix of crosses	Optical sectioning strength
Sphere	Accuracy of 3D reconstruction
3D crossing stairs	Stage drift during Z-stacking
Repositioning crosses	Stage repositioning repeatability Stage drift during timelapse
Word ARGOLIGHT	Spectral response
3D matrix of rings	None
Field of rings on a background	None
Geometrical figures	None
Grid	None

**Table 2:** Pattern and analysis correspondence in Daybook Analysis.

## 5. Description of the patterns

To know more about the functions and applications of each pattern, you can consult the “Applications guide”, available on the Argolight website: [www.argolight.com/files/Argolight-solutions\\_Applications-guide.pdf](http://www.argolight.com/files/Argolight-solutions_Applications-guide.pdf)

Documentations describing how to acquire images of these patterns and how to analyze them are available directly under the “Help” menu of Daybook Analysis.

### 5.1. Target (PAT-AG03-EM2-A2)

This pattern, depicted in Figure 9, consists of concentric circles with increasing radii from 10  $\mu\text{m}$  to 120  $\mu\text{m}$  with a step of 10  $\mu\text{m}$  featuring a target.

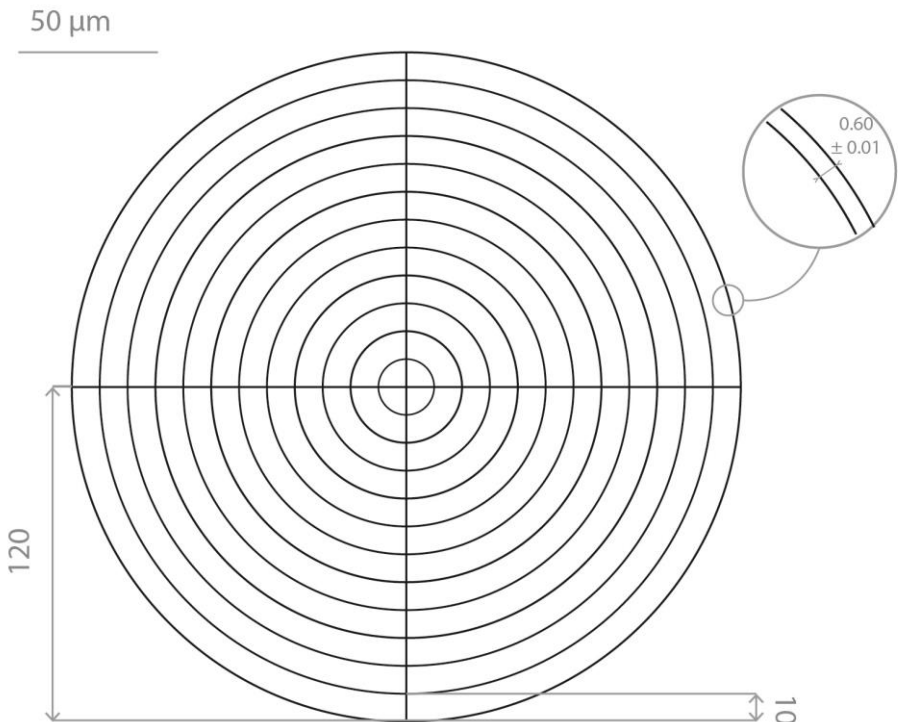

**Figure 9:** Schematics of the target. All dimensions are in  $\mu\text{m}$ .

## 5.2. Field of rings (PAT-AG03-EM2-B2)

This pattern, depicted in Figure 10, consists of a matrix of 21×21 rings, separated by 5 μm, on a total field of 100 μm × 100 μm. The field of rings is surrounded by eight landmarks and exhibits a 3 μm long cross in its center.

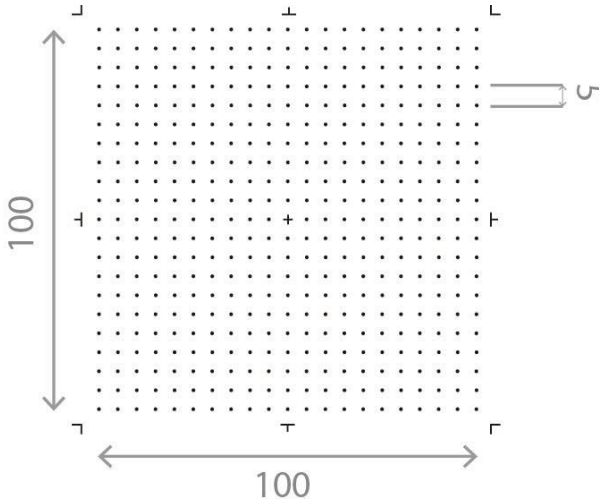

**Figure 10:** Schematics of the field of rings. All dimensions are in μm.

The typical transverse diameter (in the XY plane) of those rings is about  $(0.65 \pm 0.10)$  μm.

The typical axial length (in the Z direction) of those rings is about  $(2.30 \pm 0.30)$  μm FWHM (Full Width at Half Maximum).

### 5.3. 4x4 intensity gradation (PAT-AG03-EM2-C2)

This pattern, depicted in Figure 11, consists of sixteen  $6\ \mu\text{m}$ -wide squares having different fluorescence intensity levels following a linear evolution, organized in a  $4\times 4$  matrix.

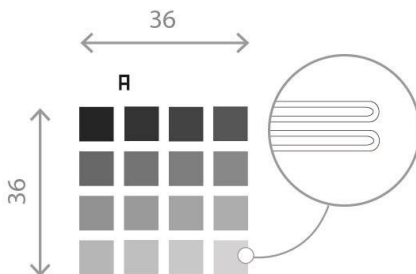

**Figure 11:** Schematics of the  $4\times 4$  intensity gradation. All dimensions are in  $\mu\text{m}$ .

### 5.4. 2x16 intensity gradation (PAT-AG03-EM2-D2)

This pattern, depicted in Figure 12, consists of twice sixteen  $15.0\ \mu\text{m} \times 0.7\ \mu\text{m}$  rectangles having different fluorescence intensity levels following a linear evolution, organized in a  $2\times 16$  matrix.

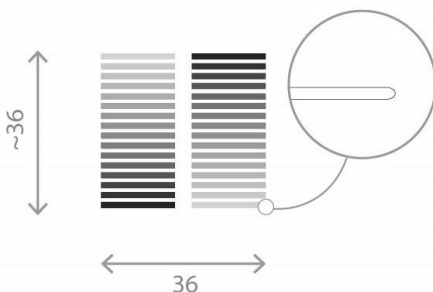

**Figure 12:** Schematics of the  $2\times 16$  intensity gradation. All dimensions are in  $\mu\text{m}$ .

### 5.5. Gradually spaced lines (PAT-AG03-EM2-E5, -E6, -E7, -E8)

This pattern, depicted in Figure 13, consists of pairs of 36  $\mu\text{m}$ -long lines whose spacing gradually increases, from 0 nm to 390 nm, with a step of 30 nm. Four sets of lines are present: one horizontal, one vertical, one ascending (+ 45°) and one descending (- 45°).

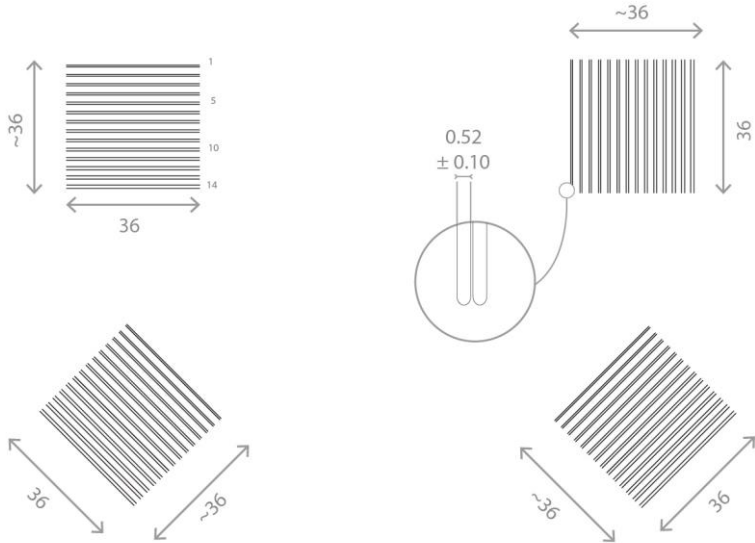

Step increase between lines: 30 nm

Line #	1	2	3	4	5	6	7	8	9	10	11	12	13	14
Spacing (nm)	0	30	60	90	120	150	180	210	240	270	300	330	360	390

**Figure 13:** Schematics of the horizontal, vertical, descending (- 45°) and ascending (+ 45°) gradually spaced lines. All dimensions are in  $\mu\text{m}$ .

## 5.6. Matrix of crosses (PAT-AG03-EM2-F2)

This pattern, depicted in Figure 14, consists of a matrix of 4×4 crosses, having a length of 5  $\mu\text{m}$  and a step of 10  $\mu\text{m}$ , surrounded by a 40  $\mu\text{m}$ -wide frame.

The crosses are composed of vertical lines that are in the same plane, and by horizontal lines, going gradually deeper within the glass. The depth difference between the vertical and horizontal lines gradually increases, from 0.1  $\mu\text{m}$  to 1.6  $\mu\text{m}$ , with a step of 0.1  $\mu\text{m}$ .

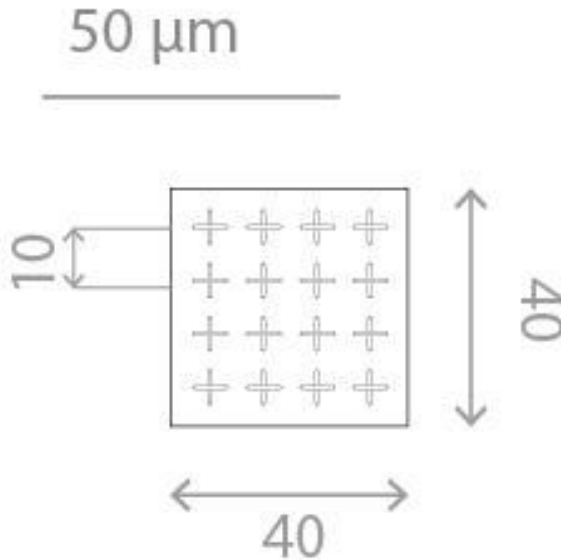

**Figure 14:** Schematics of the matrix of crosses. All dimensions are in  $\mu\text{m}$ .

### 5.7. Sphere (PAT-AG03-EM2-G2)

This pattern, depicted in Figure 15, consists of three circles with a diameter of  $25\ \mu\text{m}$  in different orthogonal planes, featuring the equator and two meridians of a sphere.

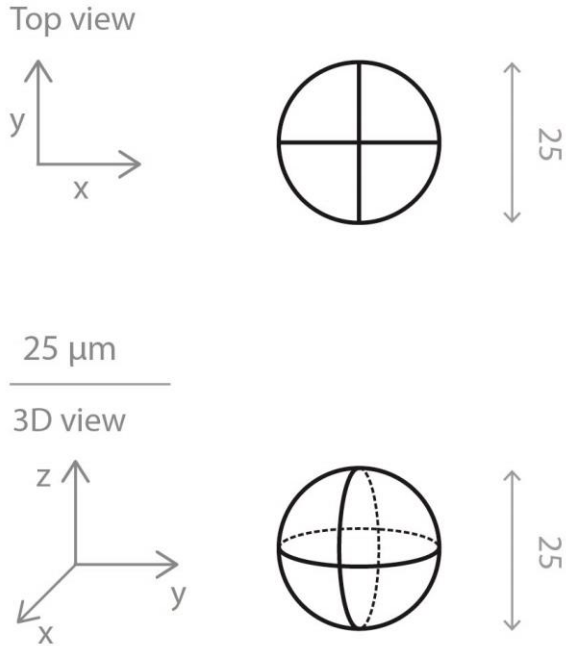
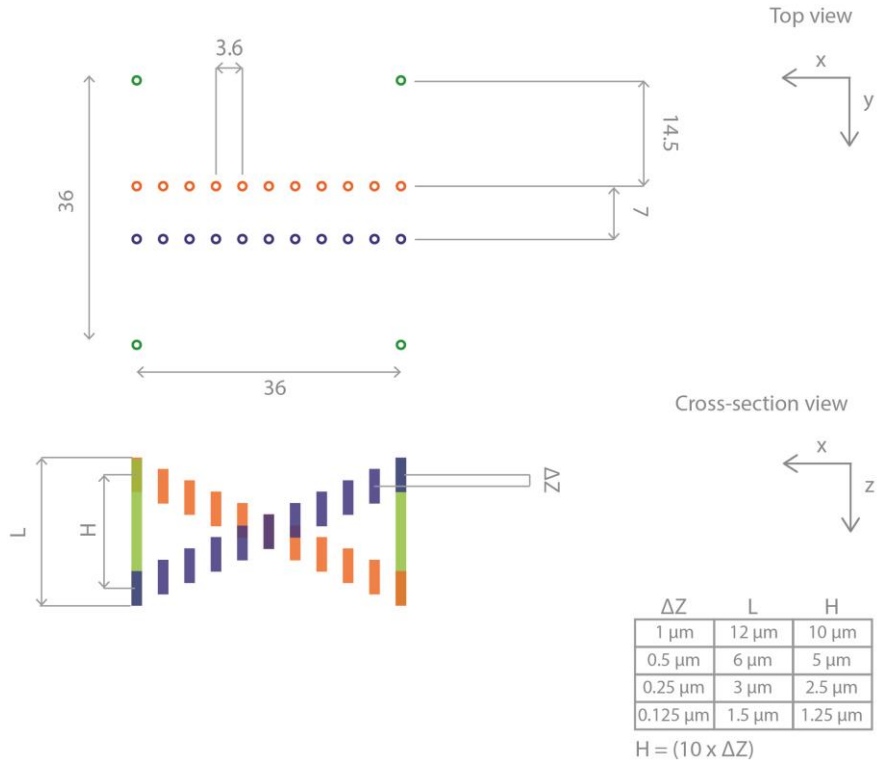

**Figure 15:** Schematics of the equator and two meridians of a sphere. All dimensions are in  $\mu\text{m}$ .

## 5.8. 3D crossing stairs (PAT-AG03-EM2-I5, -I6, -I7, -I8)

This pattern, depicted in the Figure 16, consists of twice 11 empty cylinders embedded at different depths, like two crossing stairs, surrounded by four pillars.

There are four 3D crossing stairs in the slide, with varying steps:  $1\ \mu\text{m}$ ,  $0.5\ \mu\text{m}$ ,  $0.25\ \mu\text{m}$  and  $0.125\ \mu\text{m}$ .



**Figure 16:** Schematics of the 3D crossing stairs. All dimensions are in  $\mu\text{m}$ .



### **Warning!**

Depending on the objective used to image (Z-stacking) the 3D patterns (matrix of crosses, sphere, 3D crossing stairs and 3D matrix of rings), the measured axial distances may be distorted, and shall therefore be corrected to be compared to the specified axial distances:

- For regular oil (refractive index of 1.518) objectives, designed for use with a #1.5H coverslip, there is no correction factor to apply to the measured axial distances.
- For objectives other than regular oil, designed for use with a #1.5H coverslip, the measured axial distances shall be divided by the refractive index of the immersion medium (for example: air → 1.000, water → 1.333, glycerol → 1.475) and multiplied by 1.518.

**The warning applies to the Argo-SIM only. The correction factor may change from one Argolight product to another.**

## **5.9. Repositioning crosses (PAT-AG03-EM2-H2)**

The repositioning crosses, depicted in Figure 17, are 20  $\mu\text{m}$  long and are positioned 250  $\mu\text{m}$  from one to another in the X direction, the Y direction, or both.

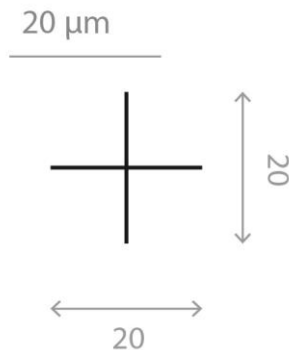

**Figure 17:** Schematics of one of the repositioning crosses. All dimensions are in  $\mu\text{m}$ .

### 5.10. Word ARGOLIGHT (PAT-AG03-EM2-J2)

This pattern, depicted in Figure 18, consists of the letters forming the company name “Argolight”, and surrounded by an  $80\ \mu\text{m} \times 18\ \mu\text{m}$  frame.



**Figure 18:** Schematics of the word ARGOLIGHT. All dimensions are in  $\mu\text{m}$ .

### 5.11. 3D matrix of rings (PAT-AG03-EM2-K1)

This pattern, depicted in Figure 19, consists in a 3D matrix of  $9 \times 9 \times 9$  rings, separated by  $5\ \mu\text{m}$ , on a total volume of  $40\ \mu\text{m} \times 40\ \mu\text{m} \times 40\ \mu\text{m}$ .

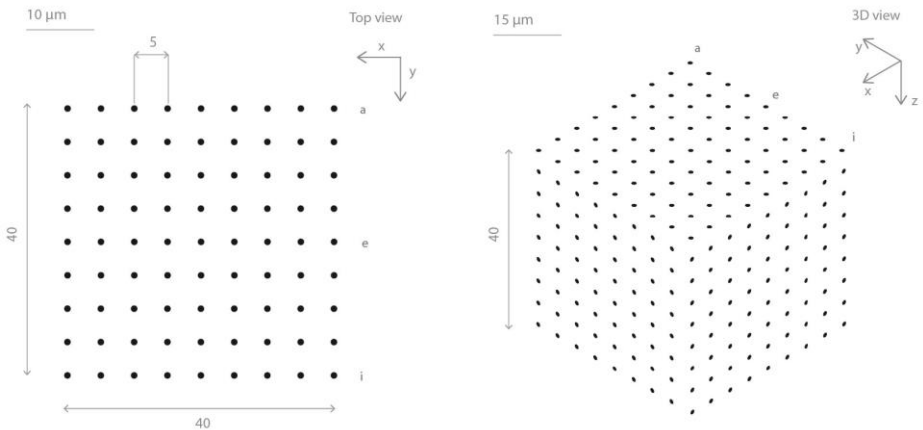

**Figure 19:** Schematics of the 3D matrix of rings. All dimensions are in  $\mu\text{m}$ .

## 5.12. Field of rings on a background (PAT-AG03-EM2-L1)

This pattern, depicted in Figure 20, consists in a matrix of 9×9 rings, separated by 5 μm, on a total field of 40 μm × 40 μm, on a fluorescent background that is 10 μm below.

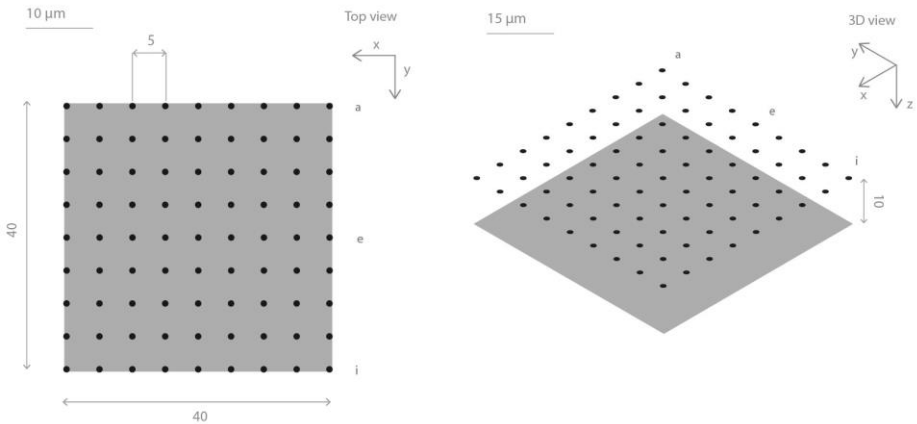

**Figure 20:** Schematics of the field of rings on a background. All dimensions are in μm.

## 5.13. Geometrical figures (PAT-AG03-EM2-M1, -M2, -M3, -M4, -M5, -M6, -M7, -M8)

The different geometrical figures, depicted in Figure 21, consists of a circle, a triangle, a square, a pentagon, a hexagon, a heptagon, an octagon and a star with 16 arms.

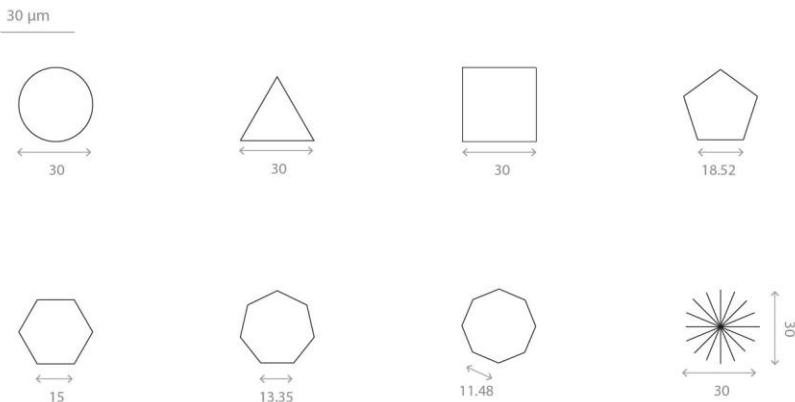

**Figure 21:** Schematics of the geometrical figures. All dimensions are in μm.

### 5.14. Grid (PAT-AG03-EM2-N1)

This pattern, depicted in Figure 22, consists of a grid with a size of  $110\ \mu\text{m} \times 110\ \mu\text{m}$  and a step of  $10\ \mu\text{m}$ , containing crosses of  $5\ \mu\text{m}$  length in five squares around the center.

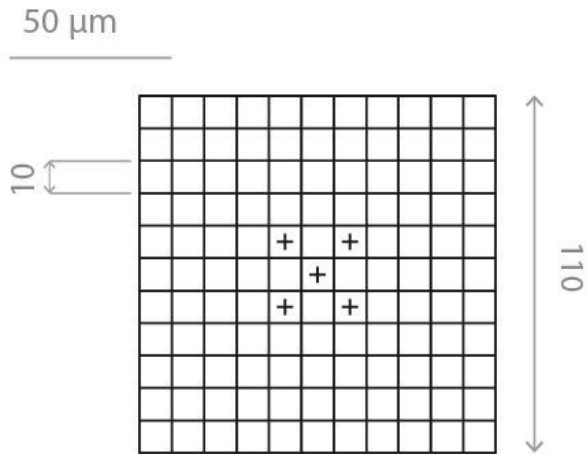

**Figure 22:** Schematics of the grid. All dimensions are in  $\mu\text{m}$ .

## 5.15. Coordinates of each pattern

Table 3 presents the XY coordinates, relative to the center of the target, of the center of each pattern, in order to help for the automation of the image acquisition.

Pattern name	Relative coordinates (X ; Y) in $\mu\text{m}$
Target	(0 ; 0)
Cross (just above the target)	(0 ; 250)
Word ARGOLIGHT	(0 ; -187.5)
Grid	(-125 ; 375)
3D matrix of rings	(-375 ; 375)
Field of rings	(125 ; 375)
Field of rings on a background	(375 ; 375)
4x4 intensity gradation	(250 ; 125)
2x16 intensity gradation	(375 ; 125)
Gradually spaced lines (horizontal)	(250 ; 0)
Gradually spaced lines (vertical)	(375 ; 0)
Gradually spaced lines (descending)	(250 ; -125)
Gradually spaced lines (ascending)	(375 ; -125)
Matrix of crosses	(-375 ; 125)
Sphere	(-250 ; 125)
3D crossing stairs ( $\Delta z = 1 \mu\text{m}$ )	(-375 ; 0)
3D crossing stairs ( $\Delta z = 0.5 \mu\text{m}$ )	(-250 ; 0)
3D crossing stairs ( $\Delta z = 0.25 \mu\text{m}$ )	(-375 ; -125)
3D crossing stairs ( $\Delta z = 0.125 \mu\text{m}$ )	(-250 ; -125)
Circle	(-187.5 ; -250)
Triangle	(-62.5 ; -250)
Square	(62.5 ; -250)
Pentagon	(187.5 ; -250)

Hexagon	(-187.5 ; -375)
Heptagon	(-62.5 ; -375)
Octagon	(62.5 ; -375)
Star	(187.5 ; -375)

**Table 3:** XY coordinates of the center of each pattern relative to the central cross.



**Date of issue:** 01/10/2021 (1<sup>st</sup> October 2021)

**User guide version:** v1.1

**Product name and version:** Argo-SIM v2.0

## Copyright notice

Copyright 2021 by Argolight SA. All rights reserved. No part of this book may be used or reproduced in any form or stored in a database or retrieval system. Making copies of any part of this book for any purpose other than your own personal use is a violation of European copyright laws.

## Contact information

Argolight SA  
Cité de la Photonique, Bdg. Elnath  
11 avenue de Canteranne  
33600 Pessac  
France  
Tel: (+33) 5 64 31 08 50  
Website: [www.argolight.com](http://www.argolight.com)  
Support: [customer@argolight.com](mailto:customer@argolight.com)

## Note for readers

The experimental data shown in this documentation are informative and not contractual. They may be different from one system to another.



### A word about waste management

Argolight policy is to offer robust and reliable products that last. In the event your product becomes useless to you, please contact us so we can pick it up and recycle it. Please do not throw away the slide with common waste. The composition of the glass requires specific recycling. Thank you.





+

+

+

+

+

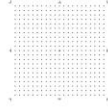
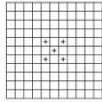

+

+

+

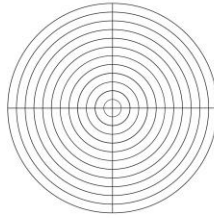

1000  $\mu\text{m}$

0500  $\mu\text{m}$

+

+

0250  $\mu\text{m}$

0125  $\mu\text{m}$



ARGOLIGHT

+



+



+

+

+

+

+

100  $\mu\text{m}$

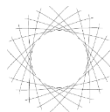

**ARGOLIGHT**  
A Precision Company